

**STRAIGHT PLUG CLAMP TYPE
CABLE .085**

R161.050.000
SERIES N

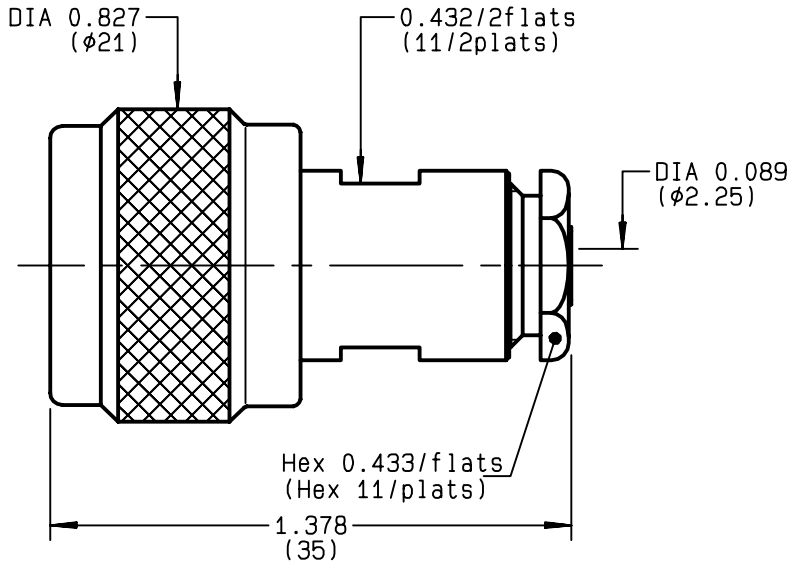

NOMINAL IMPEDANCE	50 Ω	CABLES : KS 1
FREQUENCY RANGE	0-11 GHz	RG 405
TEMPERATURE RATING	-55/+105 °C	
V.S.W.R	1.15 + x F(GHz)Maxi	
RF INSERTION LOSS	0.048 √F(GHz) dB Maxi	
VOLTAGE RATING	335 Veff Maxi	
DIELECTRIC WITHSTANDING VOLTAGE	1000 Veff Mini	
INSULATION RESISTANCE	5000 MΩMini	OTHERS CHARACTERISTICS
HERMETIC SEAL	NA Atm.cm ³ /s	CABLE RETENTION 130 N Mini
LEAKAGE (pressurized only)	NA	CENTER CONTACT RETENTION
MECHANICAL DURABILITY	500 Cycles	Axial force - mating end NA N Mini
WEIGHT	35.8 gr	Axial force - opposite end NA N Mini
SPECIFICATION		Torque NA cm.N Mini
		RECOMMENDED TORQUES
		Mating 130 cm.N
		Panel nut NA cm.N
		Clamp nut 450 cm.N

CONNECTOR PARTS	MATERIALS	FINISH	(all values are given) in micrometers
BODY	BRASS	BBR 2	
OUTER CONTACT	BRASS	BBR 2	
CENTER CONTACT	BRASS	GOLD 0.5 OVER NICKEL 2	
INSULATOR	PTFE	-	
GASKET	SILICONE RUBBER	-	
OTHERS PIECES	BRASS	BBR 2	

ISSUE 9812F01	CREATION DATE 12/10/1992	FILE PART-NUMBER EPC 96-07
-------------------------	------------------------------------	--------------------------------------



BONOMINI

The information given here is subject to change without notice.
Design changes may be in order to improve the product .

Connect to the future



R161.050.000

ISSUE **9812F01** SERIES **N**

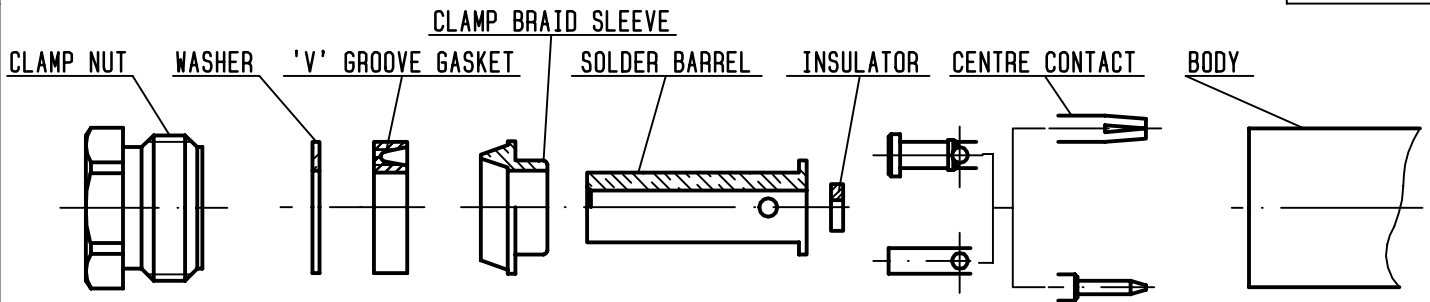

①

To take the tool kit : R 282 125 010 .
Strip the dielectric of the cable .
Stripping tool cable : R 282 051 .
Trim cable centre conductor .
Trimmer : R 282 063 .
Clean the cable .

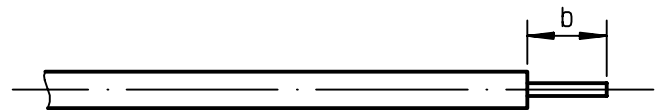

Stripping	a	b	c	d	e
inch	0	0.125 0	0	0	0
mm		3.17			

②

Slide the clamp nut , the washer , the 'V'groove gasket , the clamp braid sleeve and the solder barrel onto the cable .
Position solder barrel flush against solder barrel gauge and solder to the cable or align with outer the conductor (b) .
Solder barrel gauge : R 282 744 300 .

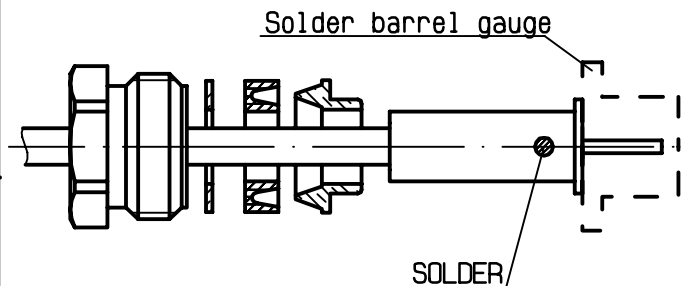

③

Once cooled , remove the solder barrel gauge.
Cut the dielectric flush to clamp braid sleeve.
Slide the insulator onto the cable inner conductor .
Slide the centre contact onto the cable inner conductor against insulator .
Fit the cable assembly onto the soldering jig R 282 740 030 and the positioner R 282 744 261 .
Tighten cable and solder the centre contact .

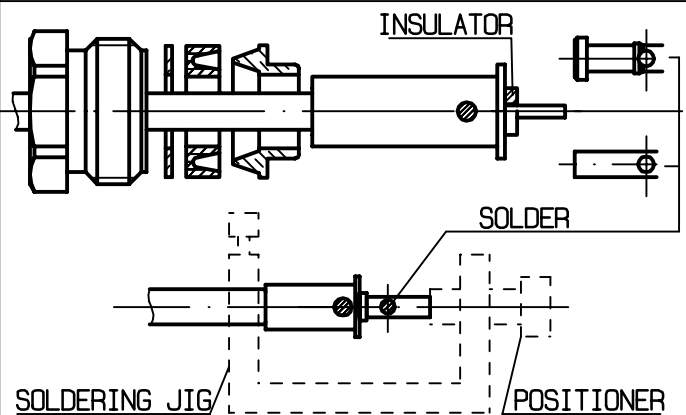

④

Screw sub-assembly into the connector body .
(recommended coupling torque 22.12 in.lb)

